



OWNER'S MANUAL

LG LED Signage

(LED SCREEN)

Please read the safety information carefully before using this product.

After reading this manual, keep it in an easily accessible location for future reference.

LSBB009-GF

LSBB009-GD

LSBB012-GD

LSBB015-GD

LSBB018-GD

www.lg.com

Copyright © 2021 LG Electronics Inc. All Rights Reserved.

TABLE OF CONTENTS

SAFETY PRECAUTIONS

- Precautions for the AC Adapter and Power
- Precautions for Moving the Product
- Precautions for Installing the Product
- Precautions for Cleaning the Product
- Precautions for Using the Product
- Precautions for Using the Remote control
- Precautions for Experiencing Image Retention
- Product Disposal

PREPARATION

1. Overview
2. Display unit appearance

INSTALLATION

1. Understanding the display unit
2. Installation plan

MAKING CONNECTIONS

Connection diagram

TROUBLESHOOTING

Troubleshooting

PRODUCT SPECIFICATIONS

Spec Sheet

WARNING

- This equipment is compliant with Class A of CISPR 32. In a residential environment this equipment may cause radio interference.

SAFETY PRECAUTIONS

The Safety Precautions are intended to prevent unexpected danger or harm by helping the user to use the product safely and for its intended purpose.

 WARNING

If you ignore the warning message, you may be seriously injured or there is a possibility of accident or death.

 CAUTION

If you ignore the caution message, you may be slightly injured or the product may be damaged.

 WARNING

This product cannot be installed outdoors. Only use the product indoors as installed by the installer.

Precautions for the AC Adapter and Power

WARNING

- Use only the power cord or AC adapter provided or approved by LG Electronics, Inc. If you use another power cord, make sure that it is certified by the national standards. If the power cable is faulty in any way, please contact the manufacturer or the nearest authorized service center for a replacement.
- Operate the display only from a power source (i.e. voltage) indicated in the product specification.
 - Otherwise the product can be damaged, fire can occur or you may be electrocuted. If you are not sure what type of power supply you have, consult a certified installation company.
- Make sure the power cord connect to a properly grounded outlet.
 - If you do not you may be electrocuted or injured or the product can be damaged.
- Insert the power plug or AC adapter firmly so it cannot come loose.
 - Poor connection may cause a fire or electric shock.
- In the presence of thunder and lightning, never touch the power cord and signal cable because it can be very dangerous.
 - It can cause electric shock.
- Be careful not to step or place heavy objects (electronic appliances, clothing, etc.) on the power cord or AC adapter. Additionally, do not bend or pull out the power cord or AC adapter with excessive force.
 - Damaged power cords may cause a fire or electric shock.
- Do not connect power cord or AC adapter damaged with sharp objects to power outlet.
 - You may be electrocuted.
- Do not insert a conductor (like a metal chopstick) into one end of the power cord while the other end is connected to the input terminal on the wall. Additionally, do not touch the power cord right after unplugged.
 - You may be electrocuted.
- Do not use with a multi-outlet connected by many electrical product and heating devices. Use an exclusive multi-outlet with a grounding terminal.
 - A fire can break out due to overheating.
- If water or any foreign substance goes inside the product, disconnect the power cord immediately and contact the service center.
 - Otherwise, this may cause a fire or electric shock due to damage to the product.
- Keep the power cord or AC adapter away from any heating devices.
 - The cord coating may melt and cause fire or electric shock.
- Never disassemble, repair or modify the power cord or AC adapter.
 - This may cause a fire or electric shock.
- Please make sure the main power cutoff device is power cord and the product is installed near the wall outlet that is easily accessible.
- As long as this unit is connected to the AC wall outlet, it is not disconnected from the AC power source even if the unit is turned off.
- Power consumption will be '0' only when the power plug is unplugged.
- Use an appliance coupler as a disconnect device.

 **CAUTION**

- If the outlet, pins of the power plug, or AC adapter is covered with dust, be sure wipe and keep clean.
 - Overheating due to layers of dust may cause a fire or electric shock.
- If the outlet, pins of the power plug, or AC adapter is covered with water, be sure wipe and keep clean. Additionally, do not touch the power plug or AC adapter with wet hands.
 - This may cause an electric shock.
- Do not turn the product on or off by plugging in or unplugging the power plug from the power outlet. It means do not use the power plug as a switch.
 - This may cause an electric shock or product malfunction.
- Do not unplug the power cord while the product is in use.
 - Electrical shock can damage the product.

Precautions for Moving the Product

WARNING

- Contact the service center before moving the product.
 - It may cause electric shock and damage the product.
- Make sure the product is turned off, unplugged, and all cables have been removed before the product is moved.
 - You may be electrocuted or the product can be damaged.
- When moving the product, Do not shock the product and impact on the front panel of the product.
 - You may be electrocuted or the product can be damaged.
- Comply with the number of people according to weight of product. (Under 25 kg per person, use the equipment when exceed 100 kg)
 - If use the damaged product again, contact the service center because it can cause electric shock or fire.
- Do not hold it upside down while holding only the stand. (It is for stand supported models only.)
 - This may cause stand warping, panel damage and other types of product damage.

CAUTION

- Do not dispose the product-packing box. It may be used put the product in the box when carrying it.

Precautions for Installing the Product

WARNING

- Contact the service center before installing the product.
 - It can cause electric shock and damage the product.
- Do not drop an object on or impact on the product. Keep out of reach of children and do not place toys or objects near the product to prevent throwing things on the product screen.
 - It can cause injury to human, problem to product and damage the display.
- Do not put heavy objects on, or hang from, the product.
 - If the product collapses or is dropped, you may be injured.
- Do not touch the surface of product to overheat.
 - It can cause injury to human.
- Install the product firmly fixed on a floor, wall, etc. to prepare against external impact such as wind and earthquake.
 - You must refer to the manual provided.
- Prevent Children from climbing or hanging on the product.
 - If the product collapses or is dropped, you may be injured.
- Do not install it where there are heating devices such as electrical heaters or lighting equipment.
 - Fire, electrical shock, malfunction may occur.
- Do not install this product by yourself as you may injure yourself or cause damage to product. Please contact service engineer authorized by service center.
- Do not install this product on a wall if it could be exposed to oil or oil mist.
 - This may damage the product and cause it to fall.
- Do not leave the power or signal cable, etc. on the pathway.
 - This could cause a trip or fall, which can be caused electrical shock, fire, product breakdown, or injury.
- Do not let the product drop when connecting it to an external device connected with a short cable.
 - This may cause injury and damage to the product.
- If you dropped the product or the case is broken, turn off the product and unplug the power cord and contact the service center.
 - If you continue to use without taking proper measures, electrical shock or fire can occur.
- Install the product in a dry place where it is not near dust and water. Avoid high temperatures and humidity.
 - This may cause electrical shock, fire or product damage.
- Safely install the product in a place that can hold the weight of the product.
 - A lack of strength may cause the product to fall.
- Take a comfortable and natural position to relax the muscles when working with a product.
- Caution to prevent damage to the LED from static. Do not touch the product without anti-static gloves.

 **CAUTION**

- Install the product where no Electromagnetic Interference occurs.
- If you install the product in a place that does not meet the recommended conditions, this may cause serious damage to the product's picture quality, life cycle, and appearance. Please check with service engineer before installing. Please do not install the product in places such as where there is an abundance of fine dust or oil mist, chemical substances are used, exposed to direct sunlight, the temperature is very high or low, the humidity is very high.
- Make sure the product is well ventilated by installing at a distance (100 mm or more) from the wall.
 - If you install the product too close to the wall, it may be deformed or fire can break out due to internal heat buildup.
- Do not cover the product with tablecloth or curtain or other material (eg. plastic) while plugged in to block the ventilation hole of the product.
 - The product can be deformed or fire can break out due to overheating inside the product.
- Do not install the product in an area with poor ventilation (e.g. on a bookshelf, in a closet) or outside and avoid placing on cushions or carpets.
 - The product could catch fire due to overheating inside the product.
- Install the product on a flat and stable place that is large enough to support the product.
 - If the product is dropped, you may be injured or the product may be broken.
- When installing the product on a shelf or cabinet, make sure that the bottom end of the product is not protruding forward.
 - The product may fall due to unbalanced center of gravity, which may cause personal injury or damage to the product. Be sure to use cabinets or shelves that fit your product.

Precautions for Cleaning the Product

WARNING

- Keep the product clean at all times.
 - If you don't clean the unit for a long time and it becomes covered in dust, it can cause fire or product damage.
- When you need to clean the inside of the product, you must contact the service center.
 - Otherwise, cleaning without support may cause a fire, electric shock, or damage to the product.
- When cleaning the product, unplug the power cord and wipe gently with a soft cloth to prevent scratching.
 - An electric shock may occur or damage to the screen as get a scratch.
- When you want to clean the front frame, spray water onto a soft cloth 2 to 4 times and wipe in one direction only.
 - Too much moisture may cause staining.
- Do not physically come in contact with the screen of the LED Package.
 - This may cause damage to the product.
- To clean the product, use an air gun to lightly remove dust from the front frame and the screen.
 - If there are foreign substances in between the LEDs on the screen, it may cause a defect in the screen.

CAUTION

- When cleaning the product or the screen, unplug the power cord and wipe it gently with a soft cloth. Do not spray water or other liquids directly on the product. Especially, do not clean your product with chemicals including glass cleaner, any type of air freshener, insecticide, lubricants, wax (car, industrial), abrasive, thinner, benzene, alcohol, etc., which can damage the product or its panel.
 - This may result in fire, electric shock or product damage (deformation, corrosion or breakage).

Precautions for Using the Product

WARNING

- Do not use the product in any environment with excessively high temperatures or humidity.
- If you use the product for a long period of time, take a rest from time to time to protect your vision.
 - Extended viewing could result in impaired vision.
- Listening at high volume or using for a long time can cause damage to your hearing.
- In the event that liquid or a foreign object falls into the product, please switch it off and unplug it from the wall outlet and contact the service center.
 - Otherwise, the product may cause fire or electric shock.
- In the event that no image appears on the screen or no sound is heard, stop using the product. Switch it off immediately, unplug it from the power outlet and contact the service center.
 - Otherwise, the product may cause fire or electric shock.
- Do not drop an object or impact on the product or screen.
 - It can cause injury to human, problem to product and damage the screen.
- If you can smell smoke or other odors or hear a strange sound, unplug the power cord and contact the service center.
 - If you continue to use the product without taking proper measures, it may cause electrical shock or fire.
- Do not attempt to disassemble, repair or modify the product yourself. Please contact service center if you need to repair it.
 - Fire or electric shock can occur.
- Do not place objects filled with liquids, such as vases, cups, etc. on over of the product to prevent liquid from entering the product.
 - Failure to do so may result in fire, electric shock, malfunction or deformation.
- Do not push hard on or scratch the product's surface with your hands or sharp objects, such as nails, pencils or pens. Do not shock or scratch the front and sides of the screen with metallic objects.
 - This may damage the products and cause it to malfunction.
- Do not touch the product if it has been exposed to sunlight or an intense light because it could be hot.
- Do not use high voltage electrical goods near the product (e.g., a bug zapper).
 - This may result in product malfunction if it receives an electrical shock.
- If there is a gas leak, do not touch the outlet, and open the windows for ventilation.
 - Otherwise, the product may cause fire or electric shock.
- If you dropped the product or the case is broken, turn off the product and unplug the power cord.
 - If you continue to use without taking proper measures, electrical shock or fire can occur. Contact the service center.
- Keep small accessories out of the reach of children.
 - If a child swallows it, consult a doctor immediately.
- Keep out of reach of children from the product. Also, do not throw toys or objects to the product or screen.
 - It can cause injury to human, problem to product and damage the screen.
- All the power sources must be disconnected by removing the power cables to remove all power from the unit.

 **CAUTION**

- This panel is an advanced product that contains millions of pixels. You may occasionally see pixel spots when viewing the screen. Since these deactivated pixels are not a defect, the performance and reliability of the product is not affected.
- Do not put or store inflammable substances near the product.
 - There is a danger of explosion or fire.
- Keep the proper distance from the product.
 - It can cause damage to your vision if you look at the product too closely.
- Set the appropriate resolution and frequency by products.
 - It can cause damage to your vision.
- Take a regular break when working with the product for a long time.

Precautions for Using the Remote control

WARNING

- Avoid places with high humidity.
 - It may cause electrical shock or damage the product.
- Do not expose batteries to excessive heat, such as direct sunlight, open fireplace, and electric heaters.
 - It may cause fire and you may be injured.
- Make sure that children do not swallow the remote control batteries when you replace them. Keep batteries out of reach of children.
 - If a child swallows a battery, consult a doctor immediately.
- Do not dispose of batteries in a fire.
 - Please dispose batteries at a local recycling center or a retail store that handles batteries.
- Used batteries, which include rechargeable batteries, should be recycled separately from waste.
 - Please dispose used batteries and rechargeable batteries at a local recycling center or a retail store that handles batteries.

CAUTION

- Do not short circuit and disassemble of batteries.
 - It may cause electrical shock or fire.
- The remote control may not function properly in sunlight or under a strong lamp. Move the product if it is being used in these conditions.
- Check if there is any obstacle between the product and the remote control.
- Do not mix new batteries with old batteries.
 - Overheating or leaking batteries may cause fire or electric shock.
- Only use the specified type of battery. Do not insert batteries that are not rechargeable into the charger.
 - Overheating or leaking batteries may cause fire or electric shock.

Precautions for Experiencing Image Retention

- Displaying a still image for a prolonged period of time may cause damage to the screen, resulting in image retention. Most third-party products have the same issue. The resulting damage is not covered by the product warranty.
- Use a screen saver when using the monitor for a prolonged period of time.

Product Disposal

- Do not dispose of this product with general household waste.
- Disposal of this product must be carried out in accordance to the regulations of your local authority.

PREPARATION

1. Overview

LSBB series LED display unit is characterized by energy efficiency, seamless tiling, high brightness, high resolution, large viewing angle, wide color gamut, and full front access.

LSBB series include 4 pixel pitch products:

Specification model	Pixel pitch (mm)	Physical resolution W×H	Unit size W×H×D (mm)
LSBB009	0.9375	640x360	600x337.5x56
LSBB012	1.25	480x270	600x337.5x56
LSBB015	1.5625	384x216	600x337.5x56
LSBB018	1.875	320x180	600x337.5x56

2. Display unit appearance



< Cabinet appearance >

INSTALLATION

Safety warning:

1. When transporting, installing and repairing the display unit cabinet or LED module, please operate carefully to avoid damage to the LEDs.
2. Installation and use in the environment of smoke, dust and water vapor are forbidden.
3. Measures against Electro-Static Discharge (ESD). Before touching the LED, touch the display installation structure or other grounded metal with your hand to release static electricity on your body and clothes, and then wear anti-static gloves. The mounting frame of the LED screen should be grounded properly.

1. Understanding the display unit

1) Size diagram of display unit

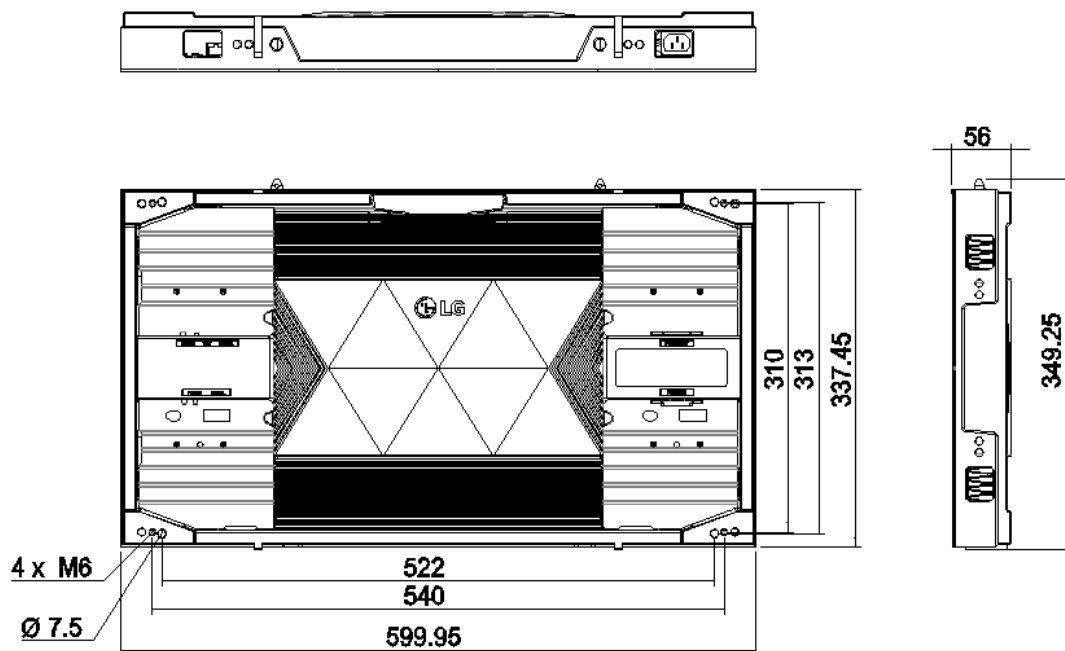

< Size diagram of cabinet >

The outer side of the cabinet is the rear mounting hole, and the inner side is the front mounting hole.

2) Six-axis adjustment

The LSBB LED display system is designed for indoor use, where a high quality

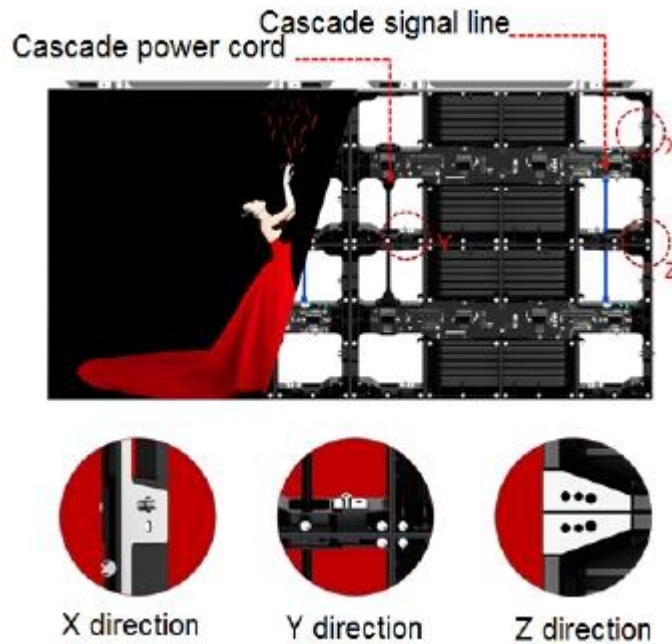

< Cascade cable and 6-axis adjustment of cabinet >

In the installation, the six-axis adjustment function is used to improve the installation accuracy. The following is the cabinet-level six-axis adjustment:

Z- direction adjustment. Z-direction adjustment function is provided at the 4 corners of the cabinet mounting Hole.

X- direction adjustment. There are 2 screws on the left and right sides of the cabinet to adjust the distance between the cabinets.

Y- direction adjustment. There are 2 screws on the upper and lower sides of the cabinet to adjust the distance between the cabinets.

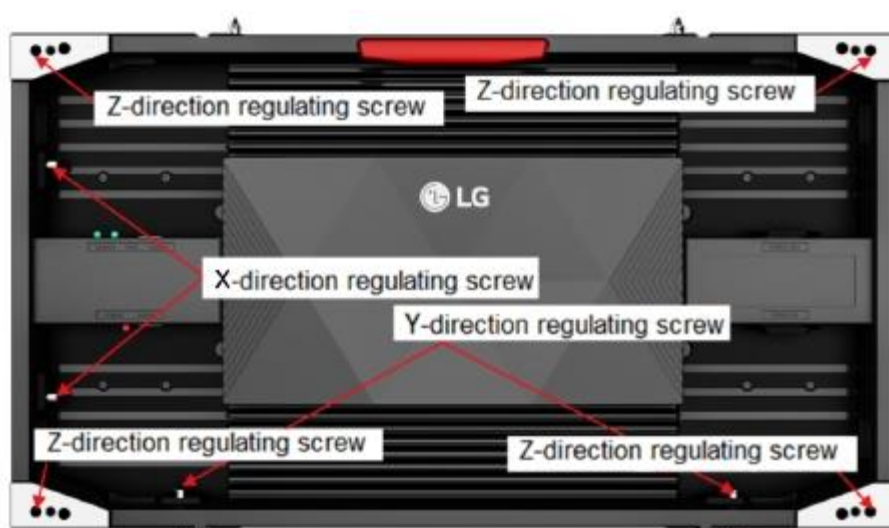

< Cabinet 6-axis adjustment position >

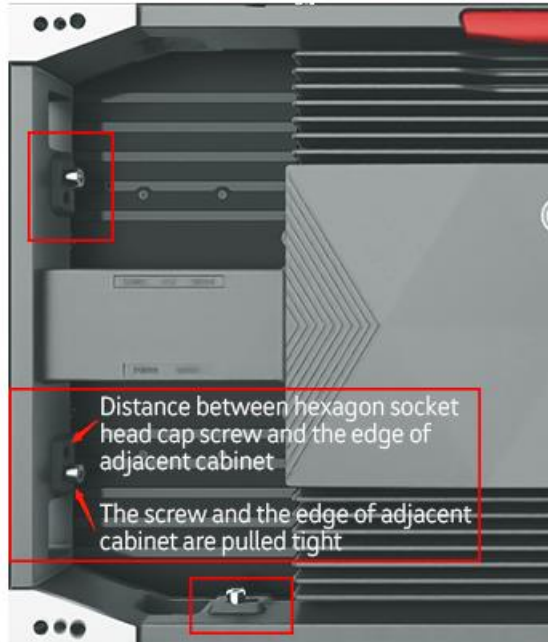

< Each adjustment point in XY direction contains 2 screws >

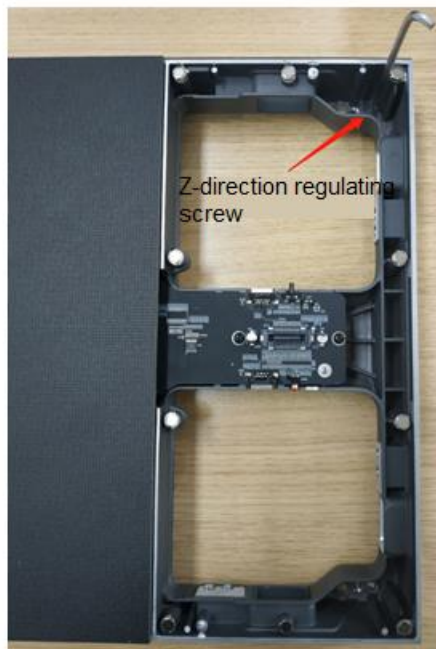

< Z-direction adjustment point >

3) Magnetic module

Remove the LED module from the front with a magnet tool.

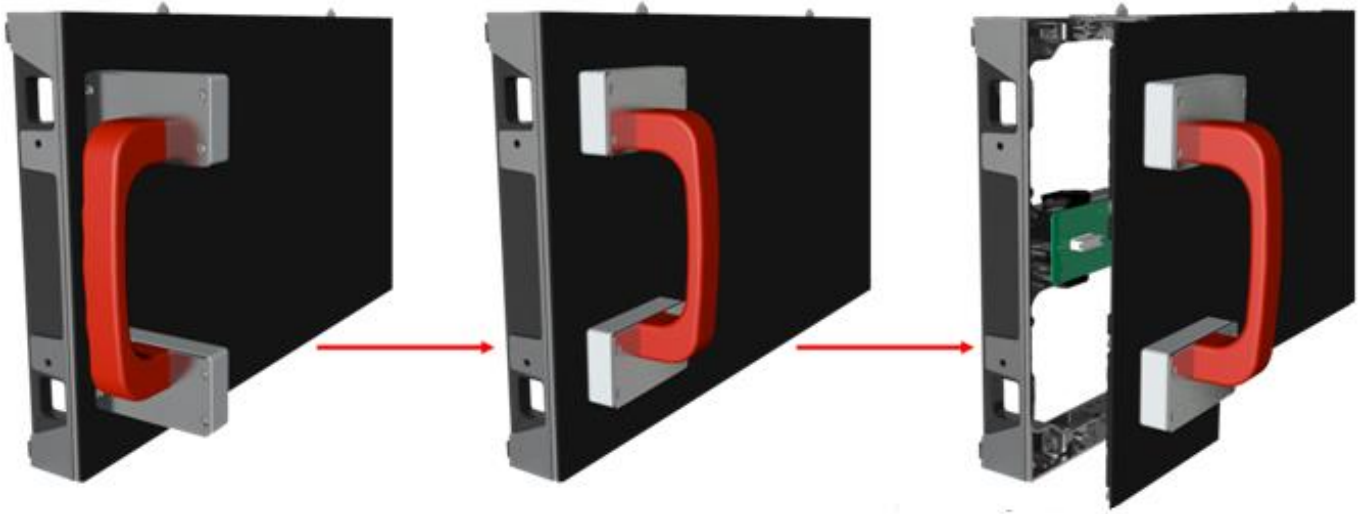

1. The magnetic tool is parallel to the LED module to be disassembled.

2. The magnetic tool approaches the LED module vertically, and the magnetic structure on the LED module starts to attract.

3. To prevent damage to the LED module, pull it out vertically to remove the module.

4) Indicator light function description

Indicator	Status	Description
Power indicator (Red)	Always on	It is always on after the power is supplied.
	Light does not shine	The cabinet is not powered or the power supply is abnormal.
Status indicator (Green)	Flashing every other 1s	Receiving card is functioning normally. Ethernet cable connection is normal, and video source input is available.
	Flashing every other 3s	Receiving card is functioning normally, but Ethernet cable connection is abnormal.
	Flashing rapidly for 3 times every other 1s	Receiving card is functioning normally. Ethernet cable connection is normal, but no video source input is available.
	Flashing rapidly every other 0.5s	Program loading fails in normal operating state, currently loading backup operating program.
	Flashing rapidly for 8 times every other 1s	Sending cards backup Ethernet port is now active. Receiving card is functioning normally.



2. Installation plan

Preparation tools (Prepared by the user)

- ① Tools for connection of connecting plates with the LED cabinet mainly include: hex wrench, adjustable spanner, socket wrench, etc.
- ② Tools needed for structure inspection and calibration include: tape, laser leveler, etc.;
- ③ Tools for adjusting the LED cabinet during installation: rubber hammer



< Hex wrench >



< Leveler >



< Rubber hammer >

Tips: Please handle with care when transporting, installing and repairing the display unit cabinets or LED modules, to avoid damaging LED due to bump

1) Option 1 - Wall mounting installation plan

2.1.1 Necessary accessories (Sold separately)

When installing and fixing each display unit at rear, 4 fixing bolts are required for each display unit, and several screws are required for each wall mounting bar (the screw head diameter not less than 8mm or a gasket with a diameter larger than 8mm is added; Recommend M6X20)

The screws for fixing the wall mounting bar will be selected based on wall's type).

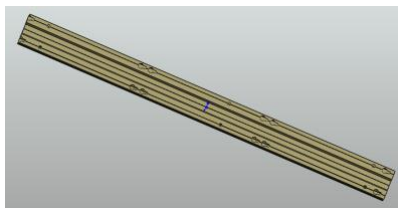

< Wall mounting bar >



< Specialized fixing bolt >

Check the holes of wall mounting bar:



2.1.2 Installation steps of wall mounting bar

Step1. After the installing position is determined, locate the holes of mounting bar with Laser leveler:



Step2. After the holes are properly located, install the mounting bar (confirm whether all bars are vertical in the same plane with the leveler after the bar is fixed, then tighten the screws and proceed to the next step):

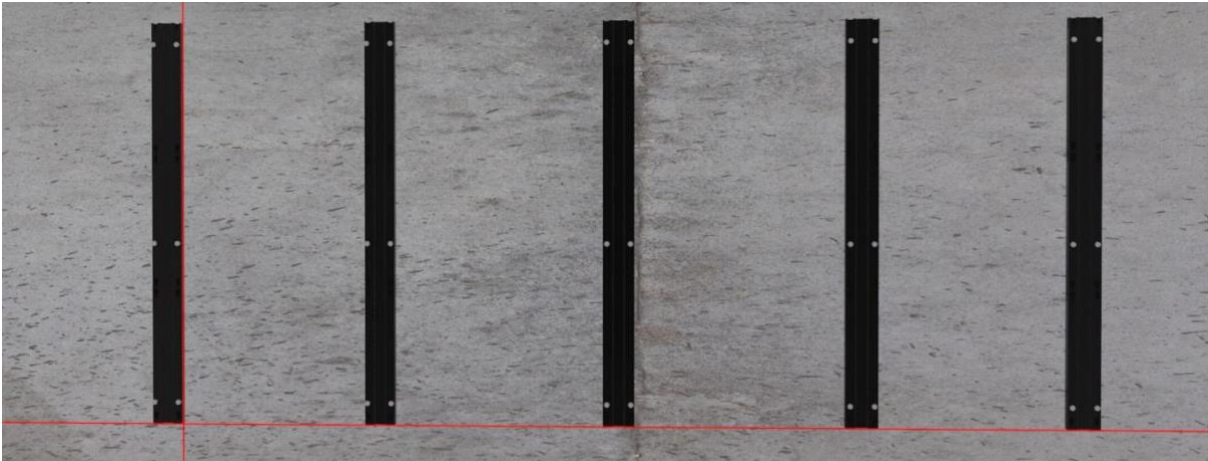

Diagrams:



When installing, be sure to align the wall mounting bar which is an 8mm through-hole. For the different projects, the fixing screws should be selected by referring to the screws of different materials (the screw head must not be less than 8mm in diameter, and the gasket larger than 8mm must be mounted for those less than 8mm)

2.1.3 Installation steps of LED cabinet

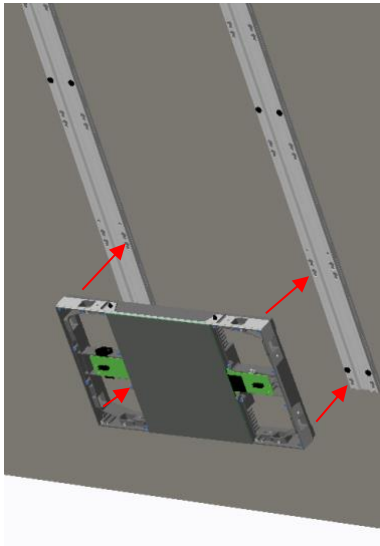

Install by aligning with the
Snowman-shaped holes

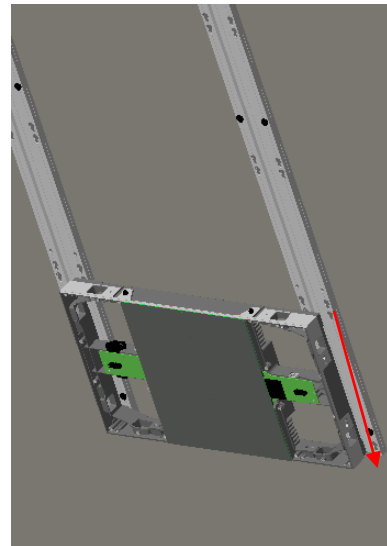

Natural hanging of
LED cabinet

Step1. Before installation, remove the modules on both sides of the LED cabinet.

The installation begins from the first layer, for which there're corresponding holes provided on the LED cabinet and mounting bar to install and fix the LED cabinets. When installing, the LED cabinet and the mounting bar are parallel to each other. After the cabinet is installed by aligning the holes, tap the top side of the cabinet gently with a rubber hammer. Make sure that the LED cabinet has been securely installed and has not been suspended.

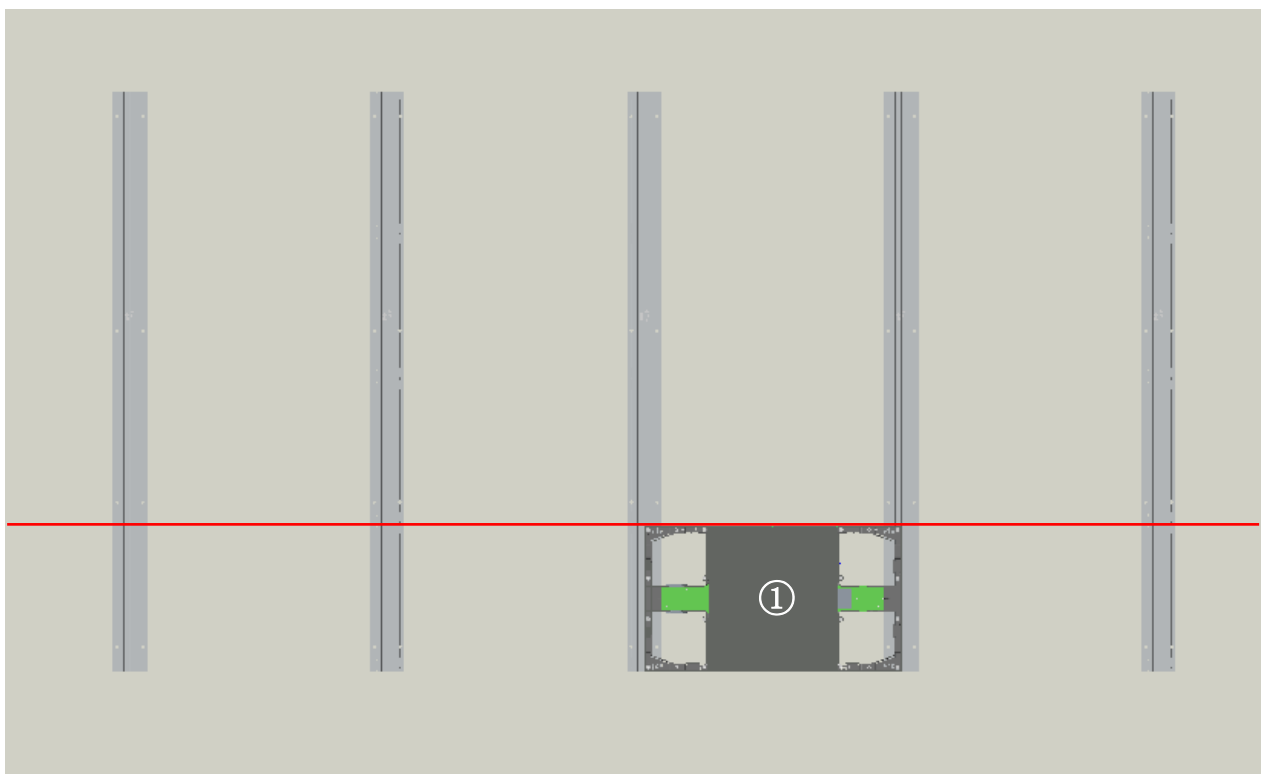

Step2. Install the second cabinet on the left side of the first one, which shall be installed in the same way as the first one. Handle and install it gently and be sure not to bump the LED cabinet next to it.

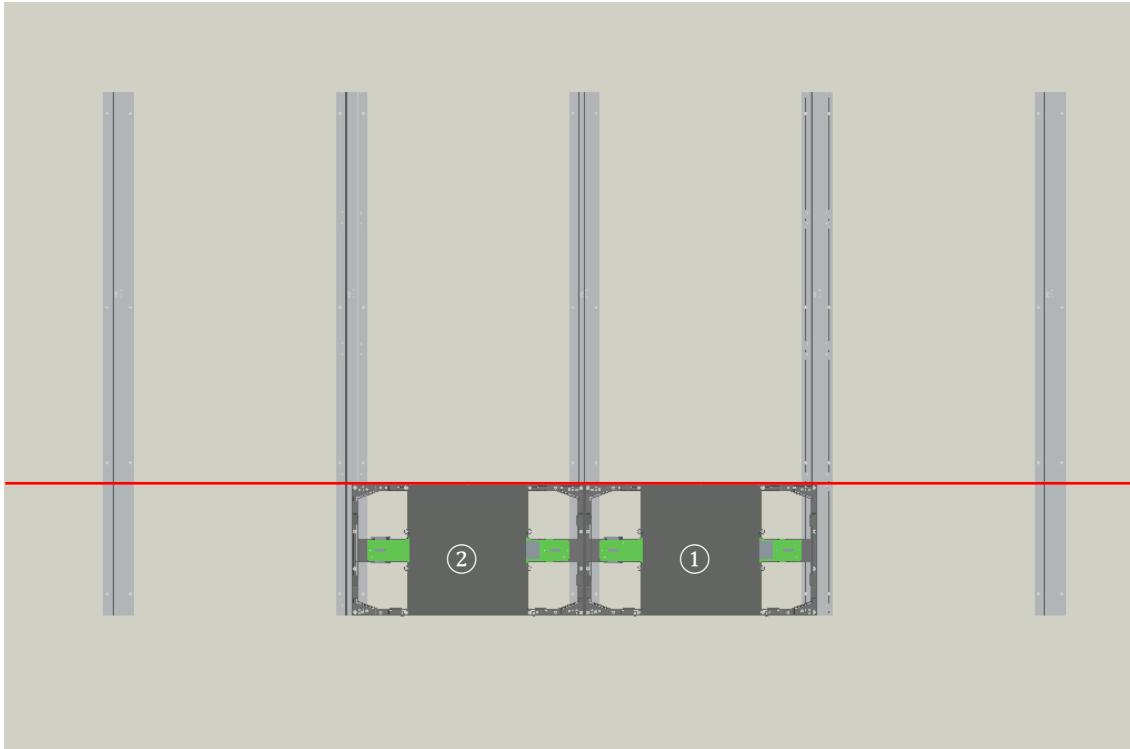

Step3. After the 1st layer is completely mounted with the same method, measure with the leveler to ensure that the LED cabinets are on the same plane. Meanwhile, plug the power and network cable according to the connection diagram of the project plan to prepare for the next step of installation.

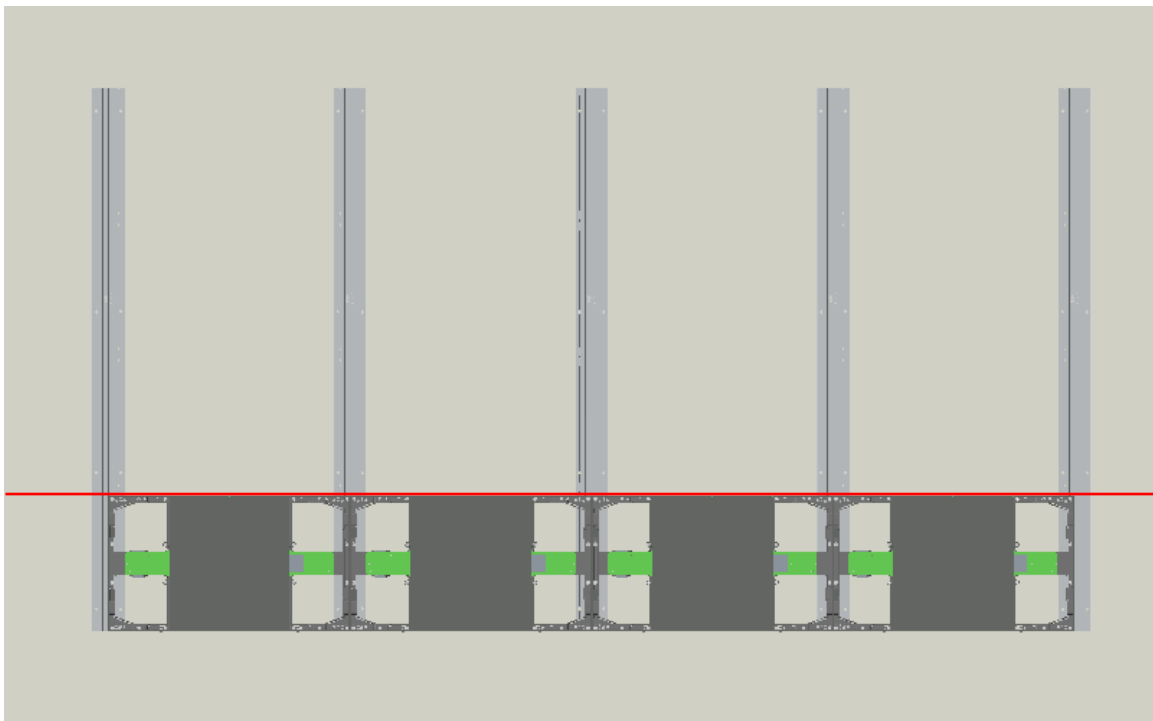

Step4. Be sure to keep flatness with the LED cabinets below when installing.

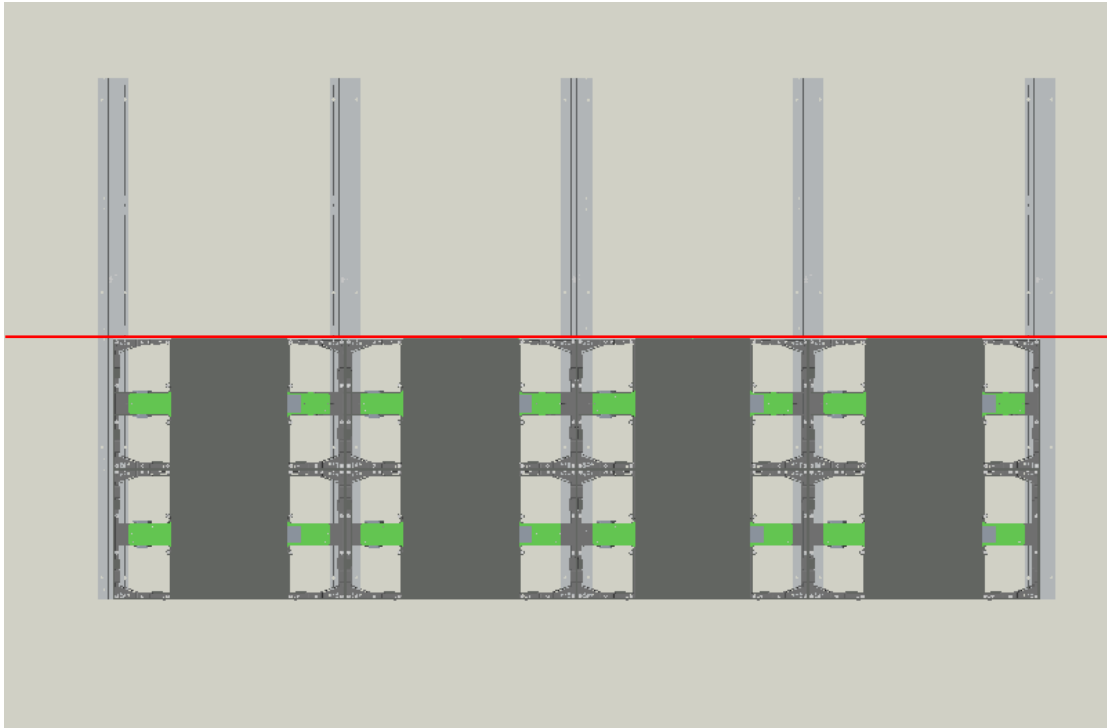

Step5. Handle the remaining LED cabinets by using the above method.

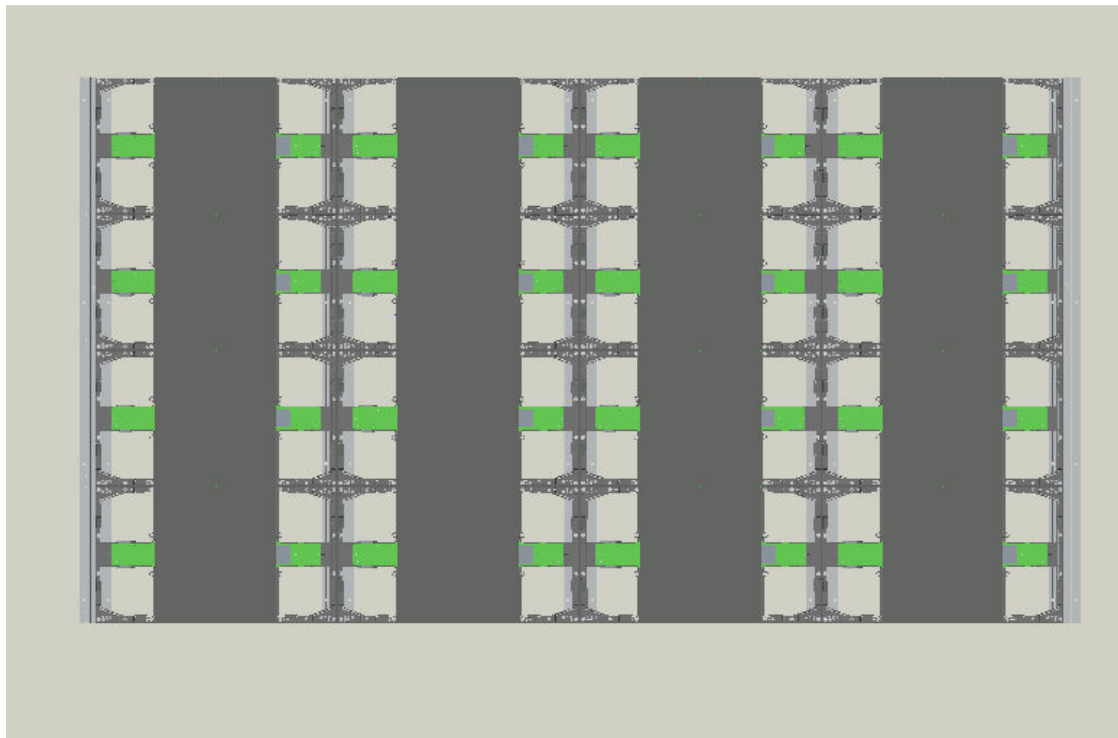

Step6. Connect the power cable and signal cable according to the system diagram.

Step7. Install the previously removed modules back to its original position before carrying out the next step.



2) Option 2 - Front installation plan

2.2.1 Necessary accessories

When fixing the display units in front installation, each display unit shall be installed with connecting plate, M6*15 hexagon screws and M6 nuts (M6 nuts sold separately).



< Half connecting plate >



< Connecting plate >



< hexagon screw M6*15 >



< M6 nut >

Check the hole of connecting plates:

Cabinet fixing hole for rear installation



Mounting hole of connecting plate

Cabinet fixing hole for front installation

Note: The hole position of the half connecting plate is the same as above

Installation diagram of the aluminum profile (sold separately):

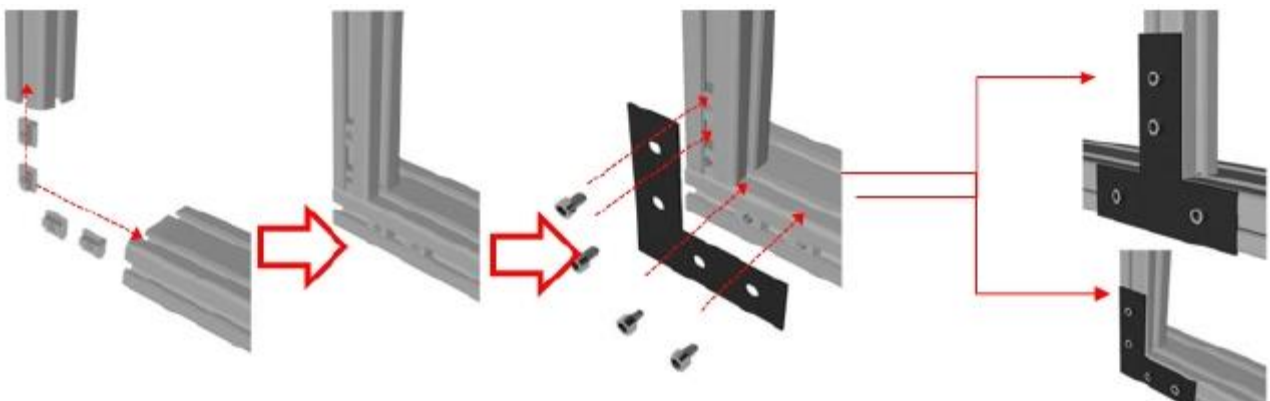

When assembling the aluminum profile, L-/T-shaped mounting parts are used for the connections between the Profiles. T-shaped mounting parts for the connection of middle profiles, while L-shaped parts, M6 hexagon screws and nuts shall be used at both ends. They shall be assembled and connected by referring to the figure above.

Installation diagram of the connecting plate:



M6 nuts and hexagon screws(M6*15) are required in this process. When installing, note that the front mounting surface of the connecting plate needs to face the fixing screws. The spacing should be reserved in advance. The connecting plates shall not be excessively tightened before LED cabinet installation to allow adjustment when there's error for the display units. The half connecting plates are used on both sides as shown below.

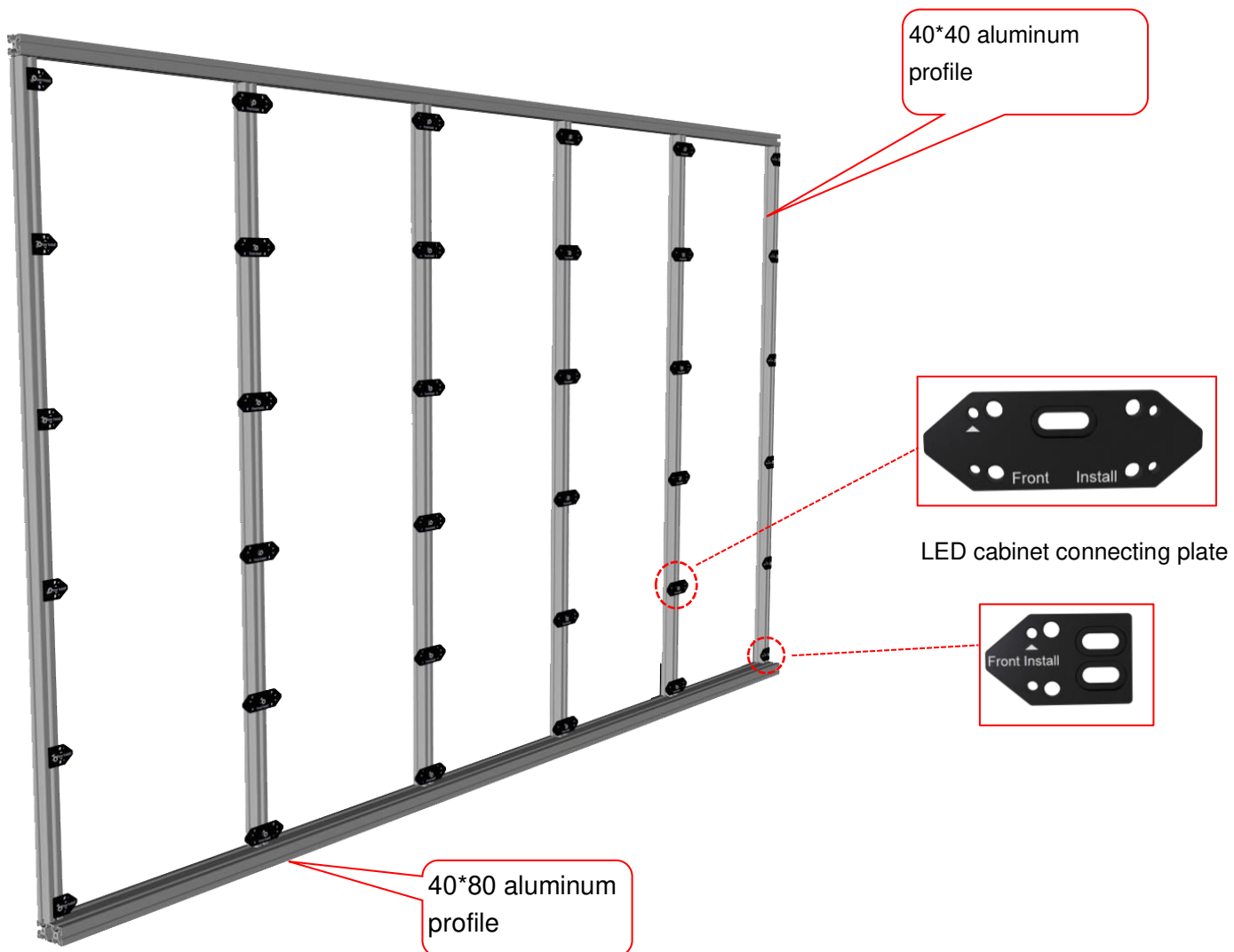

2.2.2 Installation steps of LED display screen

Step1. The drop hammer shall be used to measure the perpendicularity of each vertical member and all members shall be ensured to be on the same plane. The connecting plate shall be fastened to the vertical member of the screen according to dimensional requirements for LED cabinet installation and positioning.

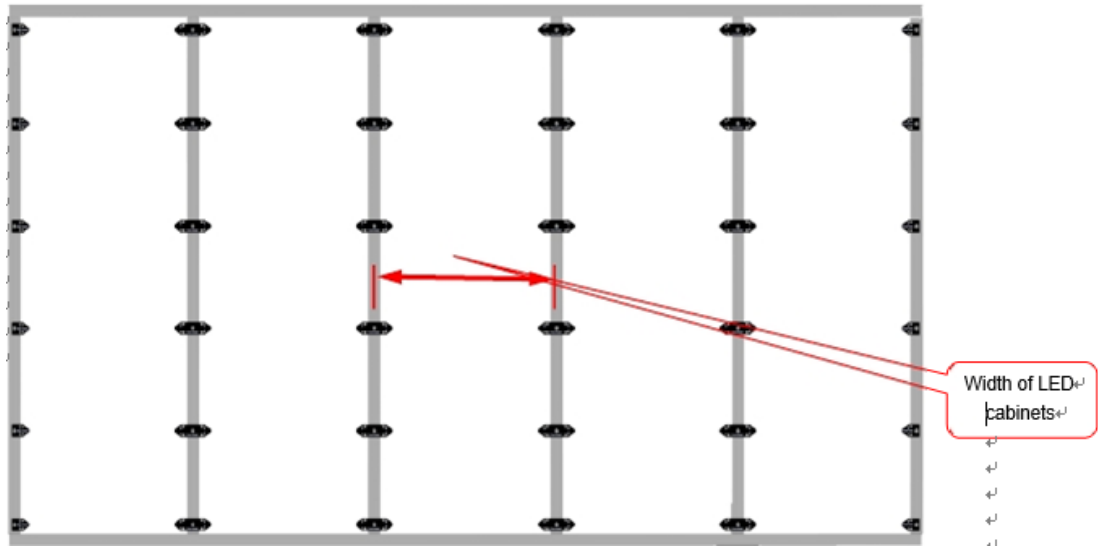

Step2. The first LED cabinet is installed in the middle of the bottom of the frame, of which the levelness and perpendicularity is adjusted by rubber hammer. The LED cabinet shall be fastened to the vertical members (40*40 aluminum profile) at both sides through its front holes with the connecting plates and M6*15 screws, but no great force shall be exerted on the bolts lest subsequent adjustments are not available. Generally, tighten the screws of the connecting plate only after the LED cabinets around the connecting plate have properly been installed.

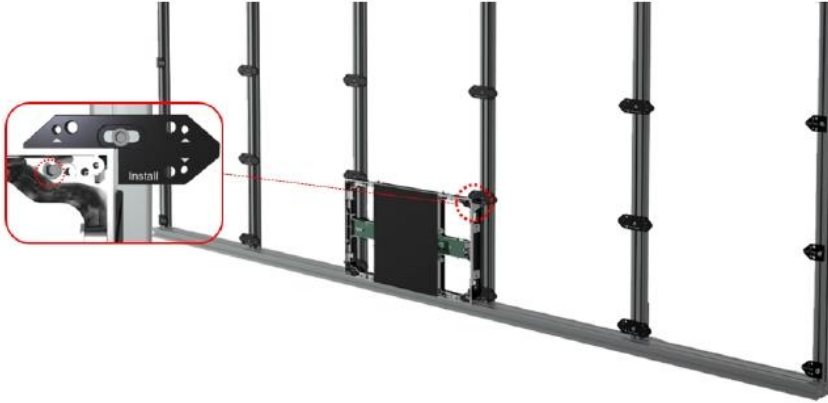

(Note: The modules on both sides of the LED cabinet must be removed carefully during front installation. Then fix the cabinet with M6*15 screws through front installation holes)

Step3. The second LED cabinet may be placed on the left of the first LED cabinet and its levelness and perpendicularity may be adjusted by rubber hammer, then the M6 screws shall be used to fasten the LED cabinets and connecting plates without exerting a great force.



Step4. The third LED cabinet may be placed on the right of the first one, and its levelness and perpendicularity may be adjusted by rubber hammer, then the M6 screws shall be used to fasten the LED cabinets and connecting plates without exerting a great force.



Step5. After installing the first row measure the perpendicularity and levelness of the LED cabinets in the first row with the leveler. Some minor adjustments can be made by rubber hammer, but excessive force is not recommended.

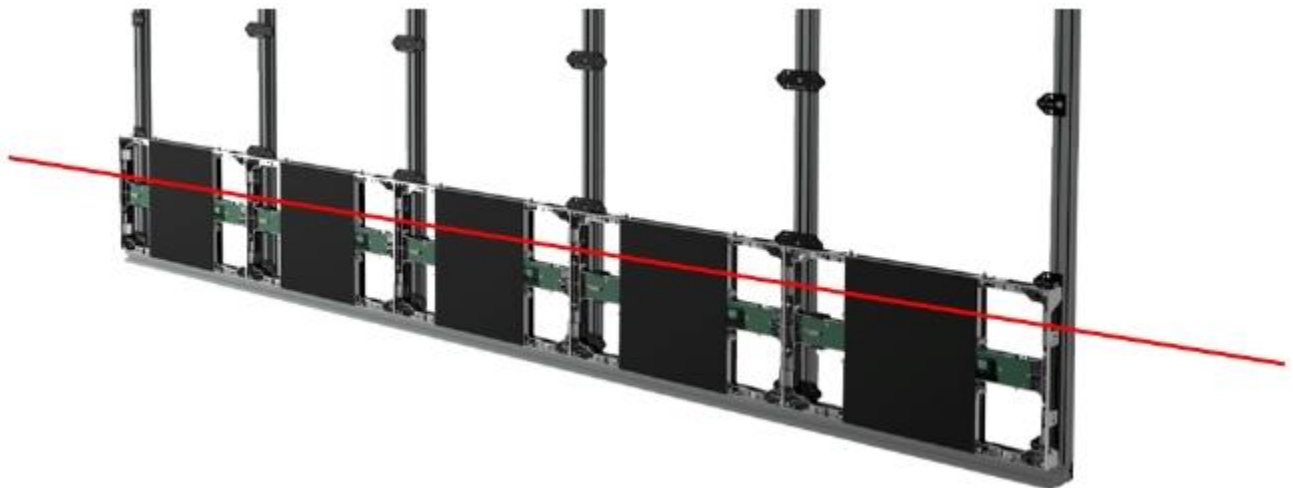

Step6. Now let's begin to install the second row of LED cabinets, firstly the cabinets shall be placed in the middle of the second row and then installed with the same installation method as that of the first row. The rubber hammer shall also be used to adjust their levelness and perpendicularity and no great force shall be exerted on the screws.



Step7. Install the second row of cabinets by using the same method, adjust the levelness and perpendicularity and screw the connecting plates between the lower row tightly.



Step8. Install the remaining LED cabinets with the same method.

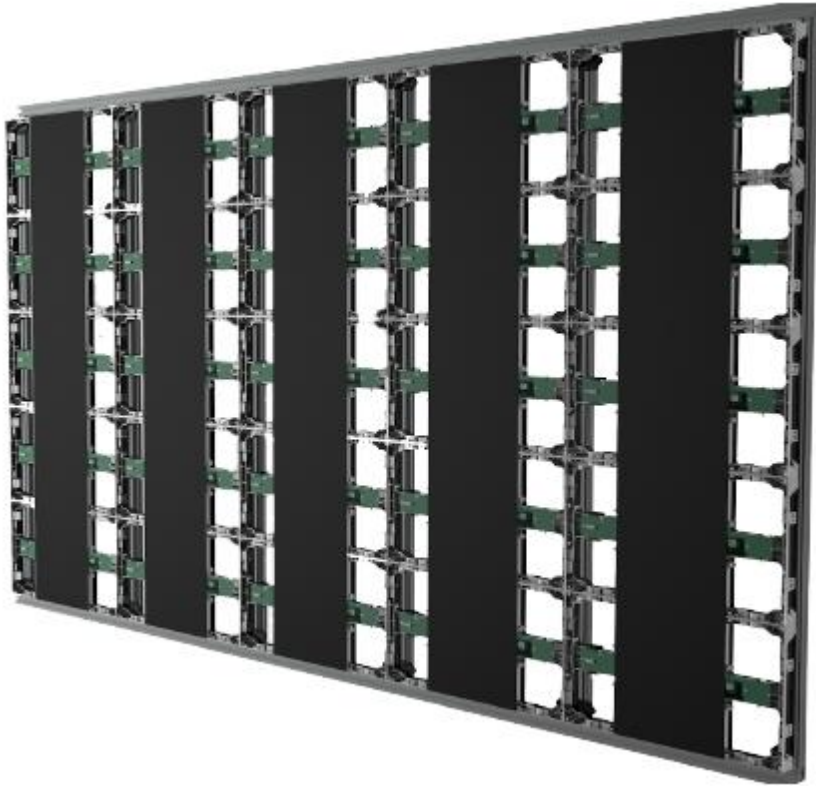

Step9. Install the previously removed modules back to its original position before carrying out the next step.



3) Option 3 - Rear installation plan

2.3.1 Necessary accessories

When fixing the display units in front installation, each display unit shall be installed with connecting plates, M6*55 hexagon screws and M6 nuts (M6 nut sold separately).



< Half connecting plate >



< Connecting plate >



< hexagon screw M6*55 >

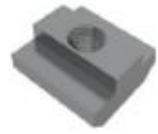

< M6 nut >

Installation diagram of the aluminum profile (Sold separately):



When assembling the aluminum profile, use the 40*40 corner fittings at the connections between profiles, and do not fasten the screws too excessively before LED cabinet installation, to allow the subsequent minor adjustment. The connection method is shown in the figure above.

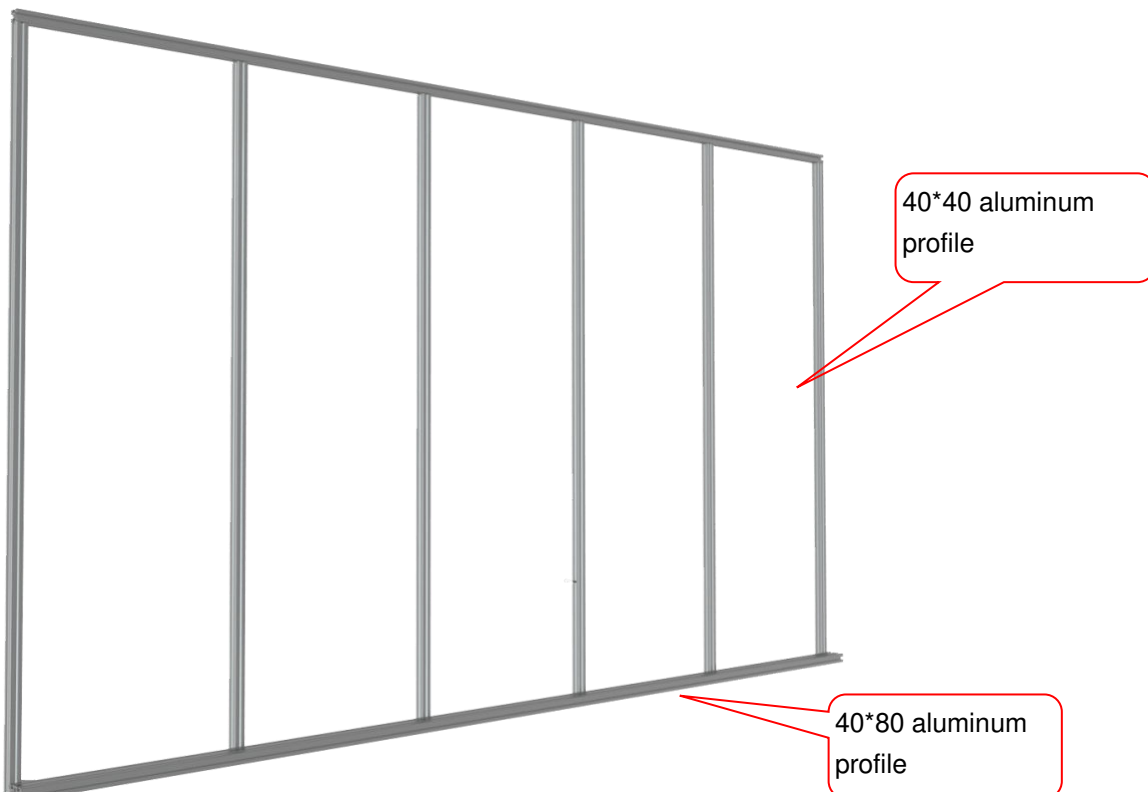

Installation diagram of the connecting plate:



The installing method for the connecting plate of rear installation are similar to that of the front installation. However, the connecting plates are fixed behind the profiles, and the M6 nuts and hexagon screws(M6*55) are required in this process. When installing, note that the front mounting surface of the connecting plate needs to face the fixing screws. The spacing should be reserved in advance. When installing the LED cabinet, the connecting plates shall not be excessively tightened to allow subsequent adjustment when there's error for the display units. The half plates are used on both sides as shown above.

2.3.2 Installation steps of LED display screen

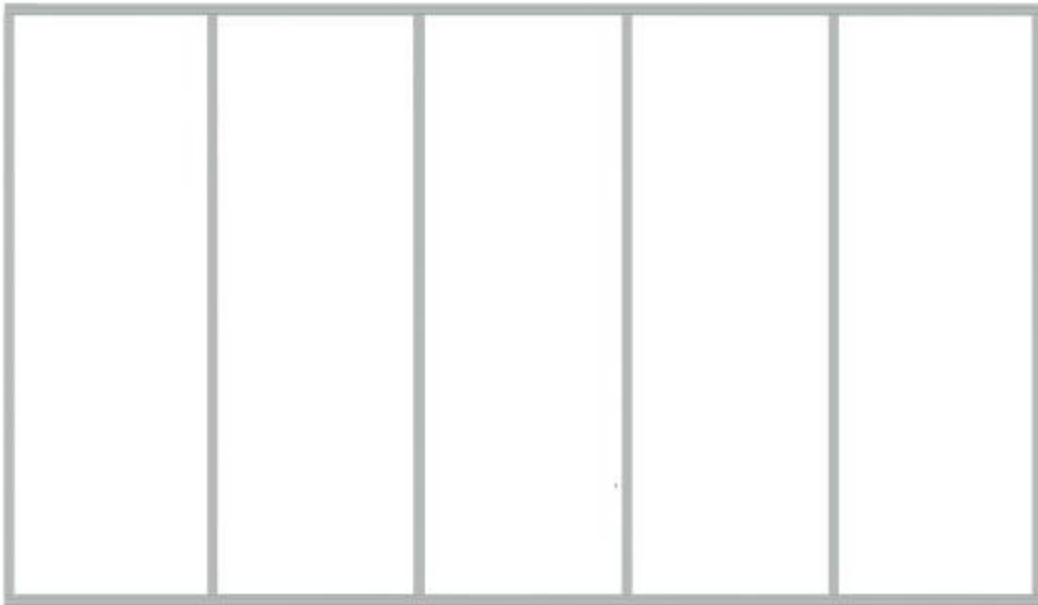

Step1. The drop hammer shall be used to measure the perpendicularity of each vertical member and all members shall be ensured to be on the same plane. The connecting plate shall be fastened to the vertical member of the screen according to dimensional requirements for LED cabinet installation and positioning. During rear installation, the connecting plate should be fixed on the back of the profile, it can be fixed with the LED cabinet after the LED cabinet is placed as shown below.

Step2. The first LED cabinet is installed in the middle of the bottom of the frame, of which the levelness and perpendicularity is adjusted by rubber hammer. The LED cabinet shall be fastened to the vertical members (40*40 aluminum profile) at both sides through its rear holes with the connecting plates and M6*55 screws, but no great force shall be exerted on the bolts lest subsequent adjustments are not available. Generally, tighten the screws of the connecting plate only after the LED cabinets around the connecting plate have properly been installed.

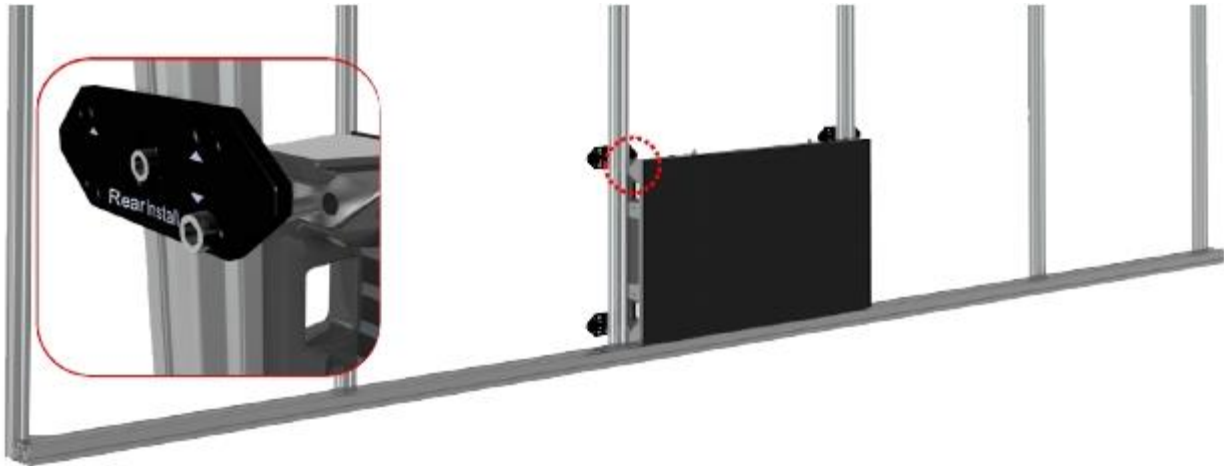

Step3. The second LED cabinet may be placed on the left of the first LED cabinet and its levelness and perpendicularity may be adjusted by rubber hammer. Then the M6*55 screws shall be used to fasten the LED cabinet and connecting plate without exerting a great force.

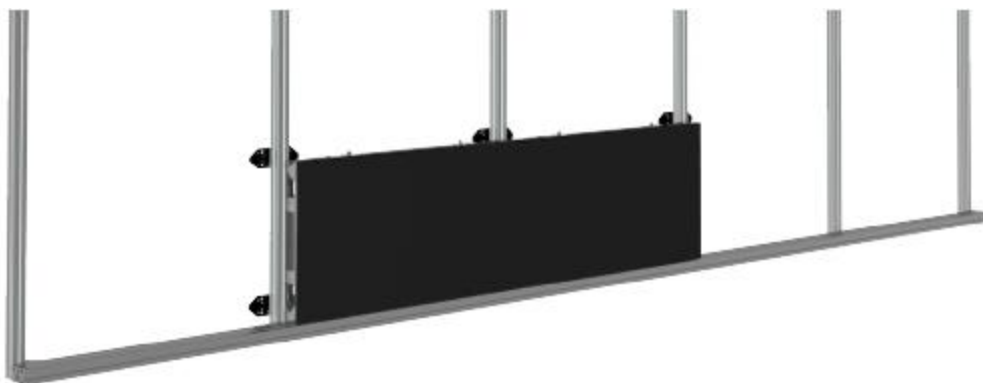

Step4. The third LED cabinet may be placed on the right of the first one, and its levelness and perpendicularity may be adjusted by rubber hammer, then the M6*55 screws shall be used to fasten the LED cabinet and connecting plates without exerting a great force.

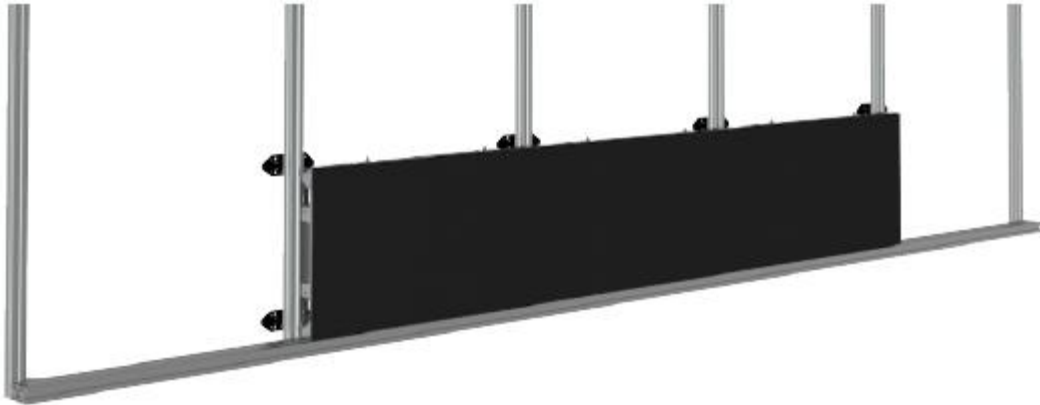

Step5. After installing the first row measure the perpendicularity and levelness of the LED cabinets in the first row with the leveler. Some minor adjustments can be made by rubber hammer, but excessive force is not recommended.

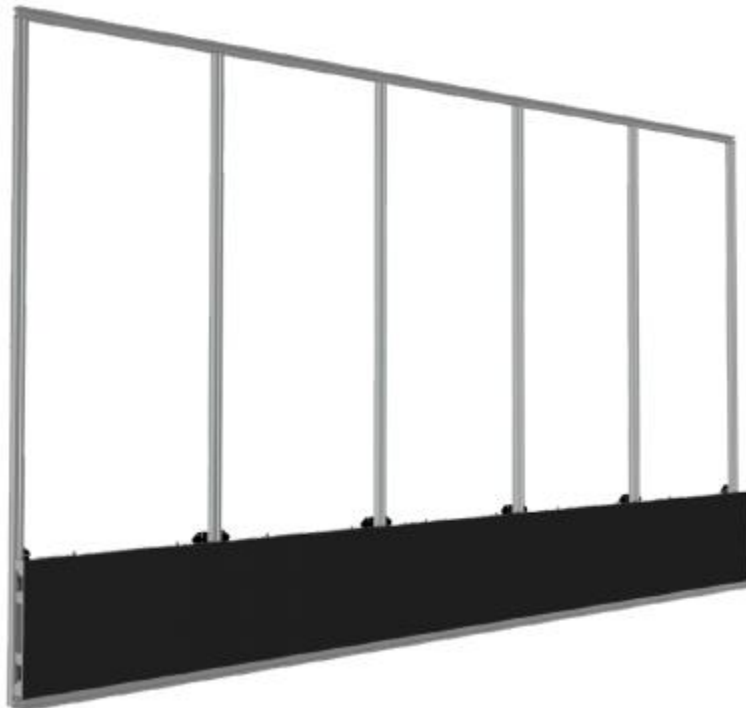

Step6. Now let's begin to install the second row of LED cabinets, firstly the cabinets shall be placed in the middle of the second row and then installed with the same installation method as that of the first row. The rubber hammer shall also be used to adjust their levelness and perpendicularity and no great force shall be exerted on the screws.

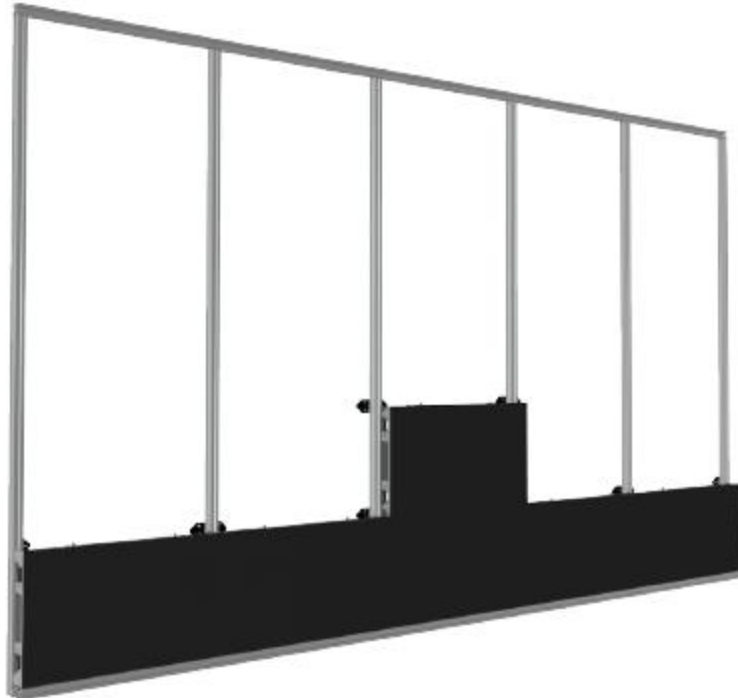

Step7. Install the second row of cabinets by using the same method, adjust the levelness and perpendicularity and screw the connecting plates between the lower row tightly.

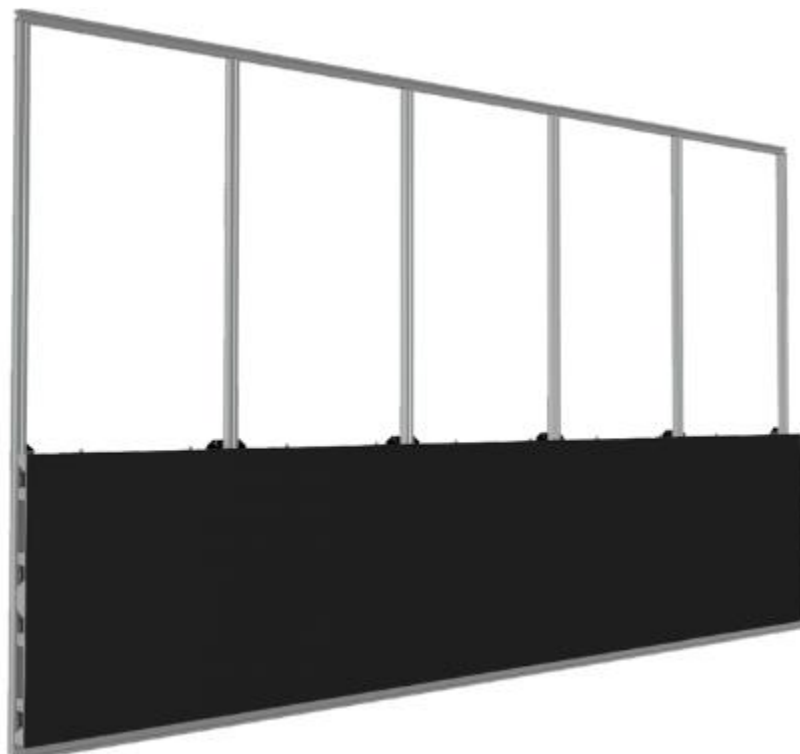

Step8. Install the remaining LED cabinets with the same method.

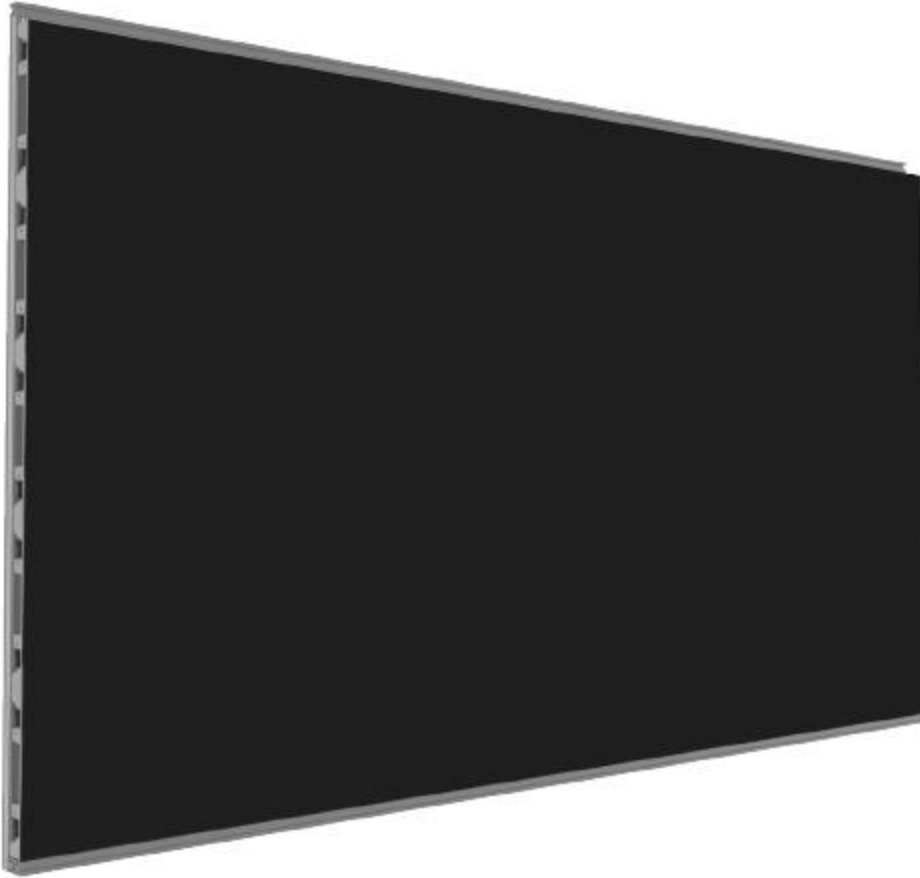

MAKING CONNECTIONS

Power signal line connection

The cabinet AC power line is cascaded up and down. AC 220V can be cascaded up to 16 cabinets. Signal control usually splices the cabinet into 2K resolution to facilitate screen image stitching. The connection method is as follows:

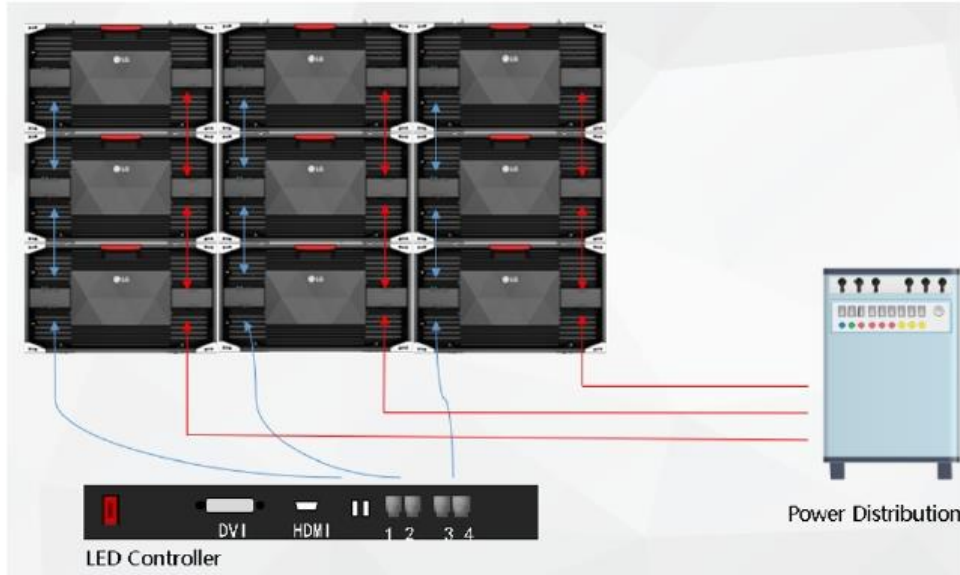

※ Note) If the communication distance between the output of the LED controller and the screen exceeds 100 m, an optical fiber transmission system is required, as shown in the following diagram:



TROUBLESHOOTING

Fault description	Solution
1. The LED screen does not display images	1. Whether the display screen power is turned on.
	2. Whether the display screen has HDMI signal input. Connect the LCD display to check whether it is caused by the signal transmission link fault.
	3. Whether the brightness setting of the display control software is normal.
2. Some LED screens do not display images	1. Whether the power supply of the display screen where the image is not displayed is normal, including input power and switching power.
	2. If no abnormality is found in the first step, the power switch of the relative area is restarted, with the power-on interval not less than 1 minute. When the power is turned on again, the problem may be solved if unit reinitialization is shown.
	3. Problem with the display unit cascade cable transmission.
	4. If the display unit image of the replaced control board cannot be connected to the periphery, software is required to set the corresponding address coordinates and brightness and color values.
3. Part of the LED screen image flickers	1. Problem with the display unit cascade signal transmission. Try to replace the cascade signal cable or control board. If the display unit image of the replaced control board cannot be connected to the periphery, software is required to set the corresponding address coordinates and brightness and color values.
	2. The problem with input signal problem. Check by connecting the LCD display.
	3. The processor resolution exceeds the maximum resolution of the sending card
	4. Problem with the screen power supply
4. The display of the LED display module is abnormal, all or part of the module lacks color and is on, and is out of control or half out of control	1. The initialization of the display unit is abnormal. Restart the power of the area at an interval of no less than 1 minute. Sometimes it may take 2-3 times to eliminate the problem.
	2. If the problem is not solved in step 1, according to the preliminary judgment, the problem may be caused by poor contact between the LED module and the control board, and the problem with poor physical contact can be solved by replugging them.
	3. If the problem in the above two steps still exists, the problem is judged to lie in the LED module or the control board circuit. Replace the LED module or the control board, and adjust the coordinates, color, and brightness to make it consistent with the color of the level image.
	4. The set resolution of the cabinet is inconsistent with the actual resolution
5. The video window image is incomplete	1. Connect the LCD display to check whether the signal input or output of the video processor is normal.
	2. Check whether the input signal resolution is inconsistent with the saved set resolution.
	3. Check whether the setting of the video processor is correct.
6. The sending card is not detected	1. The device does not supply power normally
	2. The serial cable or computer USB interface is damaged
	3. The serial port is occupied by other software
	4. Serial port driver is not installed in the computer

When the LED display is abnormal, it is necessary to comprehensively analyze which part of the display screen incurs the problem based on experience and in combination with different situations. If the problem is finally determined to lie in a component in the display unit, it is recommended to replace the component directly on site. For example, LED light board module, power supply or LED control board, etc. After replacement of the LED module, software is required to read back the data to the LED control board. After replacement of the LED control board, software settings are required.

SPECIFICATION

Parameter name		LSBB009-GD	LSBB009-GF	LSBB012-GD	LSBB015-GD	LSBB018-GD
Module	Pixel configuration	SMD 3in1	SMD 3in1	SMD 3in1	SMD 3in1	SMD 3in1
	Pixel pitch (mm)	0.9375	0.9375	1.25	1.5625	1.875
	Module resolution (W×H)	160×360	160×360	120×270	96×216	80×180
	Module size (W×H, mm)	150×337.5				
	Weight per Module(kg)	0.5				
Cabinet	Unit composition (W×H)	4×1	4×1	4×1	4×1	4×1
	Unit resolution (W×H)	640×360	640×360	480×270	384×216	320×180
	Unit size (W×H×D, mm)	600×337.5×56				
	Unit area (m ²)	0.2025				
	Weight (kg/cabinet; kg/m ²)	6.9 ; 35				
	Pixel density (pixel/m ²)	1137777	1137777	640000	409600	284444
	Flatness of unit case(mm)	0.5				
	Unit case material	Die casting aluminum				
	IP rating	IP50				
Optical parameters	Brightness (nits)	600				
	Color temperature (K)	3,200~9,300				
	Viewing angle (horiz; vert) °	160 :140				
	Brightness uniformity	≥97%				
	Color uniformity	± 0.003Cx, Cy				
	Contrast	5000:1				
	Processing depth	16(HDR10, HDR10 Pro)				
Electrical parameters	Power Consumption (W/cabinet, Max.)	140	120			
	Power Consumption (W/m ² , Max.)	700	600			
	Power Consumption (BTU/Cabinet, Max.)	478	409			
	Input voltage (V)	AC100~240V (50-60Hz)				
	Service access	Front				
	Refresh rate (Hz)	3840				
	Frame rate (Hz)	50&60				
Working parameters	Operating temperature range (°C)	-20 to 40				
	Storage temperature range (°C)	-30 to 60				
	Operating humidity range (RH)	Operating: 10 to 80%				
	Storage humidity range (RH)	Storage: 10 to 80%				



The model and serial number of the product are located on the back and on one side of the product.

Record them below in case you ever need service.

MODEL _____

SERIAL NO. _____

Temporary noise is normal when powering ON or OFF this device.